

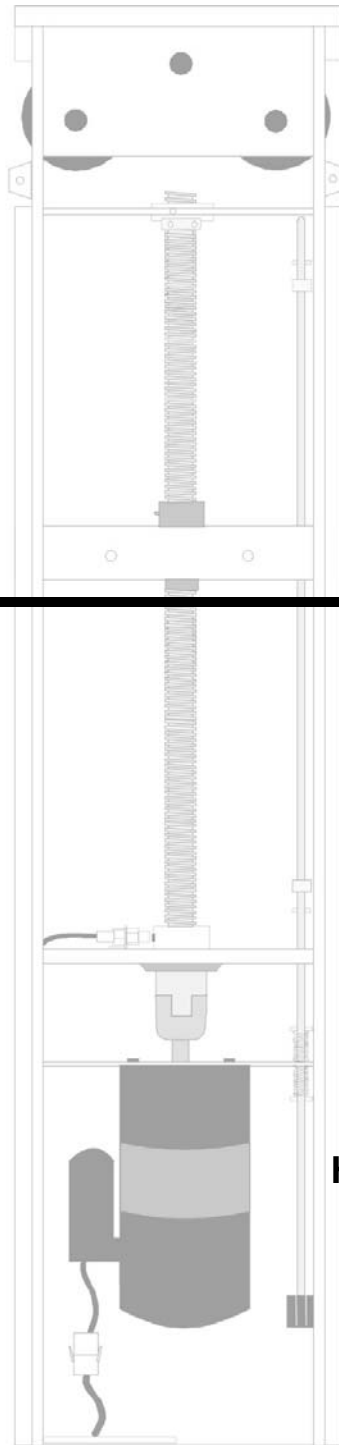

HIRED-HAND®



PowerTrak

Curtain/Vent Actuator

Hired Hand Manufacturing, Inc.
1759 County Road 68
PO Box 110
Bremen, Alabama 35033

Table of Contents

1.	Warranty	3
2.	Ratings and specifications	4
3.	Warnings	4
4.	Physical Description/Drawing	5
5.	Use of Equipment	6
6.	Installation	6
6.1	Tools Required	6
6.2	Instructions	6
7.	Maintenance	11
8.	Wiring Diagrams, Schematics, etc.....	12
9.	Electro-Mechanical Controllers.....	14
10.	Cabling Options.....	15
11.	Exploded View Diagram/Parts List	20
12.	Notes.....	23



Limited Warranty

1. Warranty

The GSI Group, LLC. ("GSI") warrants products which it manufactures to be free of defects in materials and workmanship under normal usage and conditions for a period of 12 months after sale to the original end-user or if a foreign sale, 14 months from arrival at port of discharge, whichever is earlier. The end-user's sole remedy (and GSI's only obligation) is to repair or replace, at GSI's option and expense, products that in GSI's judgment, contain a material defect in materials or workmanship. Expenses incurred by or on behalf of the end-user without prior written authorization from the GSI Warranty Group shall be the sole responsibility of the end-user.

Warranty Extensions: The Limited Warranty period is extended for the following products:

	Product	Warranty Period
AP Fans and Flooring	Performer Series Direct Drive Fan Motor	3 Years
	All Fiberglass Housings	Lifetime
	All Fiberglass Propellers	Lifetime
Cumberland Feeding/Watering Systems	Feeder System Pan Assemblies	5 Years **
	Feed Tubes (1.75" & 2.00")	10 Years *
	Centerless Augers	10 Years *
	Watering Nipples	10 Years *
Grain Systems	Grain Bin Structural Design	5 Years
Grain Systems Farm Fans Zimmerman	Portable & Tower Dryers	2 Years
	Portable & Tower Dryer Frames and Internal Infrastructure †	5 Years

* Warranty prorated from list price:
 0 to 3 years – no cost to end-user
 3 to 5 years – end-user pays 25%
 5 to 7 years – end-user pays 50%
 7 to 10 years – end user pays 75%

** Warranty prorated from list price:
 0 to 3 years – no cost to end-user
 3 to 5 years – end-user pays 50%

† Motors, burner components and moving parts not included. Portable Dryer screens included. Tower Dryer screens not included.

GSI further warrants that the frame, basket and excluding all auger and auger drive components of the portable and tower drier shall be free from defects in materials for a period of time beginning on the twelfth (12th) month from the date of purchase and continuing until the sixtieth (60th) month from the date of purchase (extended warranty period). During the extended warranty period, GSI will replace the frame or basket components that prove to be defective under normal conditions of use without charge, excluding the labor, transportation, and/or shipping costs incurred in the performance of this extended warranty.

Conditions and Limitations:

THERE ARE NO WARRANTIES THAT EXTEND BEYOND THE LIMITED WARRANTY DESCRIPTION SET FORTH ABOVE. SPECIFICALLY, GSI MAKES NO FURTHER WARRANTY OF ANY KIND, EXPRESS OR IMPLIED, INCLUDING, WITHOUT LIMITATION, WARRANTIES OF MERCHANTABILITY OR FITNESS FOR A PARTICULAR PURPOSE OR USE IN CONNECTION WITH: (i) PRODUCT MANUFACTURED OR SOLD BY GSI OR (ii) ANY ADVICE, INSTRUCTION, RECOMMENDATION OR SUGGESTION PROVIDED BY AN AGENT, REPRESENTATIVE OR EMPLOYEE OF GSI REGARDING OR RELATED TO THE CONFIGURATION, INSTALLATION, LAYOUT, SUITABILITY FOR A PARTICULAR PURPOSE, OR DESIGN OF SUCH PRODUCTS.

GSI shall not be liable for any direct, indirect, incidental or consequential damages, including, without limitation, loss of anticipated profits or benefits. The sole and exclusive remedy is set forth in the Limited Warranty, which shall not exceed the amount paid for the product purchased. This warranty is not transferable and applies only to the original end-user. GSI shall have no obligation or responsibility for any representations or warranties made by or on behalf of any dealer, agent or distributor.

GSI assumes no responsibility for claims resulting from construction defects or unauthorized modifications to products which it manufactured. Modifications to products not specifically delineated in the manual accompanying the equipment at initial sale will void the Limited Warranty.

This Limited Warranty shall not extend to products or parts which have been damaged by negligent use, misuse, alteration, accident or which have been improperly/inadequately maintained. This Limited Warranty extends solely to products manufactured by GSI.

Prior to installation, the end-user has the responsibility to comply with federal, state and local codes which apply to the location and installation of products manufactured or sold by GSI.

2. Ratings and specifications

120/240V

5000 lbs. Maximum

Important!

Electrical wiring for the PowerTrak should be at least 14 gauge, but all wiring should be in accordance with National Electric Code or other local codes.

3. Warnings

Warning!

High Voltage present inside the machine. If you need to reach inside the machine, disconnect power to the machine first.

Warning!

Dangerous Rotating Machinery. Keep hands, clothing, etc. clear when operating.

4. Physical Description/Drawing

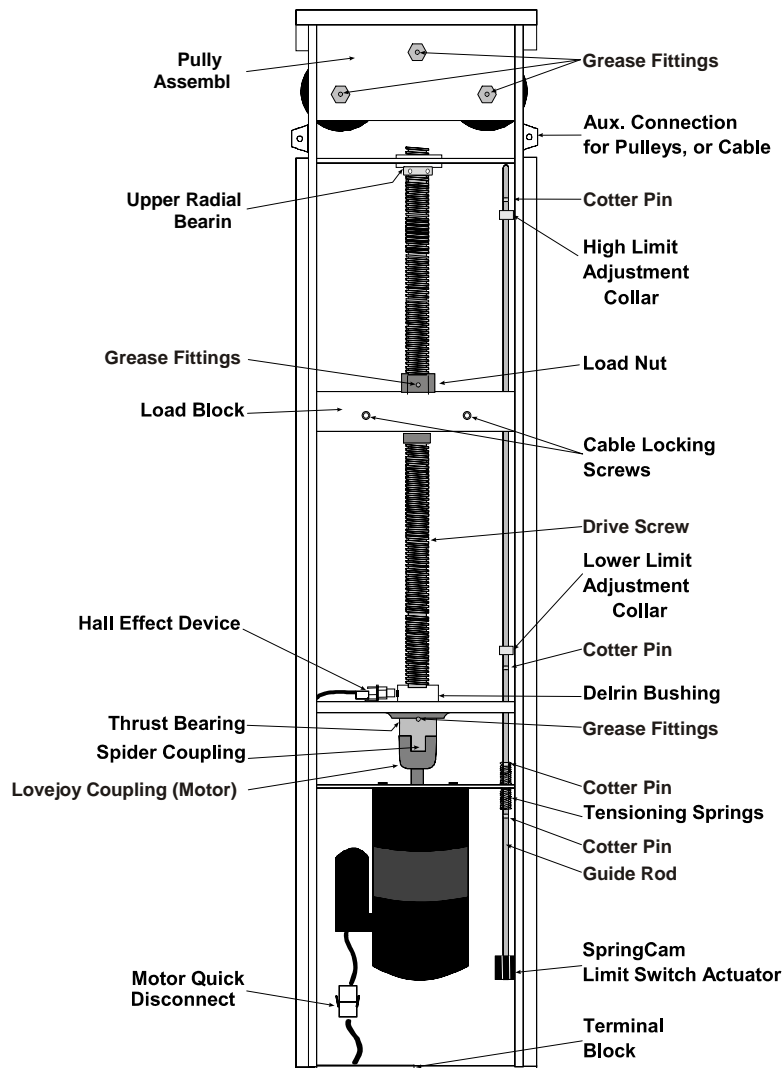

Limit Switch Assembly

The Limit Switch Assembly includes the limit switches, tensioning springs, guide rod, cotter pins, and adjustment collars. These components work together to stop the motor when the machine reaches the end of its travel. The auxiliary switches allow you to hook up equipment that should run/not run when the curtains are closed, or all the way open.

Drive Assembly

The drive assembly includes the Motor, bearings, coupling, screw, and the load block. The PowerTrak motor you have depends upon the speed of the machine you ordered. You may have a 15, 30, or 60 RPM motor.

Pulley Assembly

The pulley assembly is at the top of the machine. It consists of three pulleys which are spaced to allow the cables to go out both sides of the machine for two curtain operation, or you can run both cables out of the same side for one curtain operation. NOTE: An optional chain and sprocket assembly is also available which can be used instead of the pulley assembly.

Wiring Harness

The wiring harness includes all connectors, and wiring to route power through the limit switches, and to the motor. See wiring diagram in the back of this manual for detailed wiring instructions.

5. Use of Equipment

The PowerTrak is used for the automatic or manual operation of curtains, vents, and doors, by the use of a cable/pulley system. In the back of the manual are a few of the optional installations. These are not the only ways to cable the system, just a few typical examples.

6. Installation

6.1 Tools Required

9/16" Socket
Cable Cutters
Allen Wrench

3/8" Ratchet and extensions
Small Screwdriver
Wire Strippers

6.2 Instructions

1. Unpack the PowerTrak and check the machine for any physical defects. Open door, then remove door by pulling up or down on the spring loaded hinge pins.
2. Select mounting configuration chart from back of this manual (outside endwall, inside center, etc.) which best fits your needs.

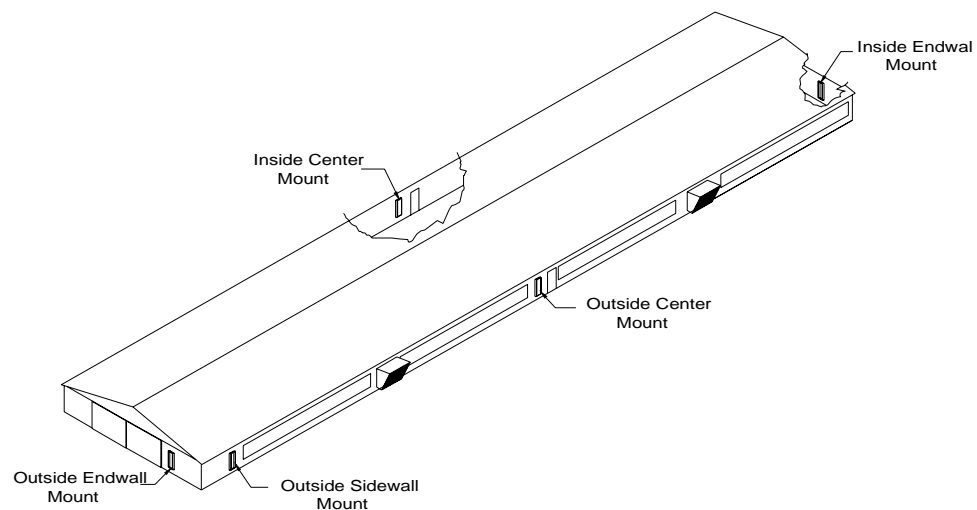

3. Drive one 3/8" lag bolt through the wall of the building in the desired location. Note: Place this bolt 5.5" below the desired height of the top of the machine.

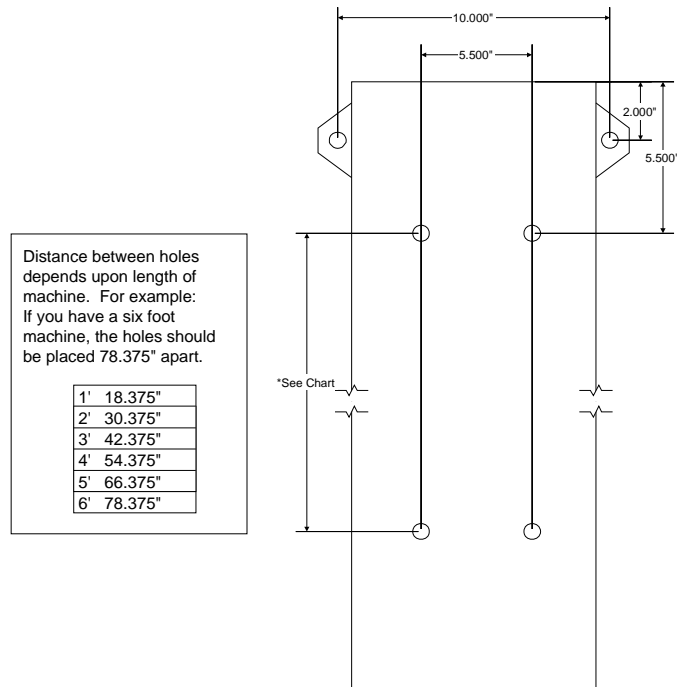

4. Hang PowerTrak on the lag bolt through the slot near the top of the machine. (See number one below) Note: This bolt is just for hanging the PowerTrak during installation. Do not attempt to operate the machine until it is fully secured. To secure the PowerTrak, use the remaining six 3/8" lag bolts provided. Drive the bolts through the four holes in the back wall of the PowerTrak (Number two below), and the two flange holes near the top (number three below).

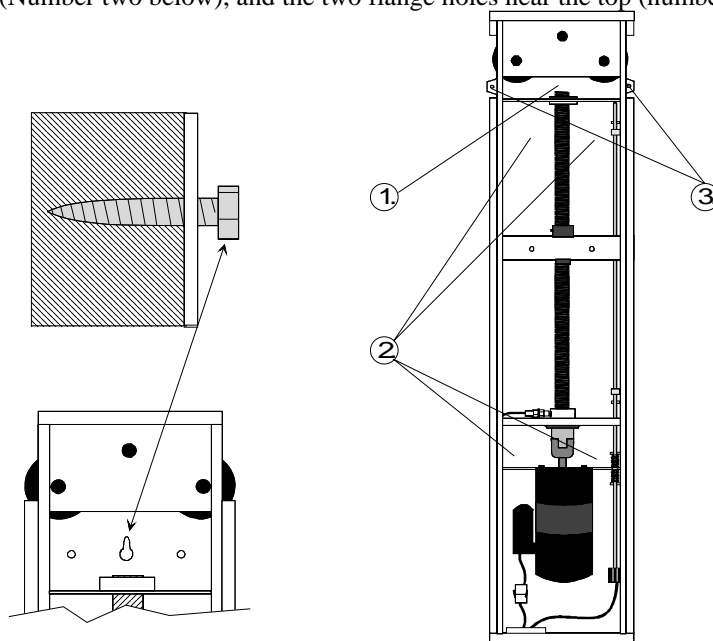

5. Install corner brackets, hand winches, thru-wall brackets, etc. as shown on the charts in the "Cabling Options" section of this manual. Care should be taken when installing brackets, pulleys, etc. to ensure that cabling will not interfere with normal operation of doors, windows, etc. It is important to use only needle bearing pulleys on any "live" pulley (one that turns every time the curtain moves) as this will extend the life of the machine, and cables.
6. Run cabling through pulleys and brackets as shown on chart selected.

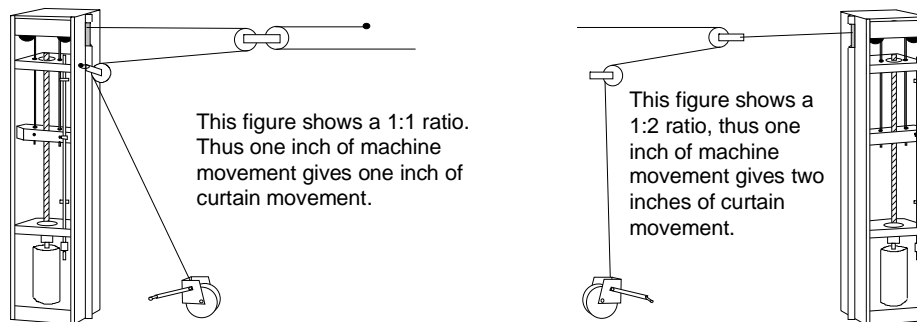

7. When hooking up the cables, leave the load nut near the closed position (The PowerTrak should have been shipped in this position). This guarantees that the manual winches will have enough cable to allow manual operation of the curtains.
8. Run ends of cables through the pulley assembly to the load block. On the load block you will find 4 holes on the top surface. Run the cables down the holes toward the center of the block, loop around and come up through the holes toward the outside of the block. Tighten the set screws on the face of the load block to lock down cables. Pull the cable through the pulleys as shown below.

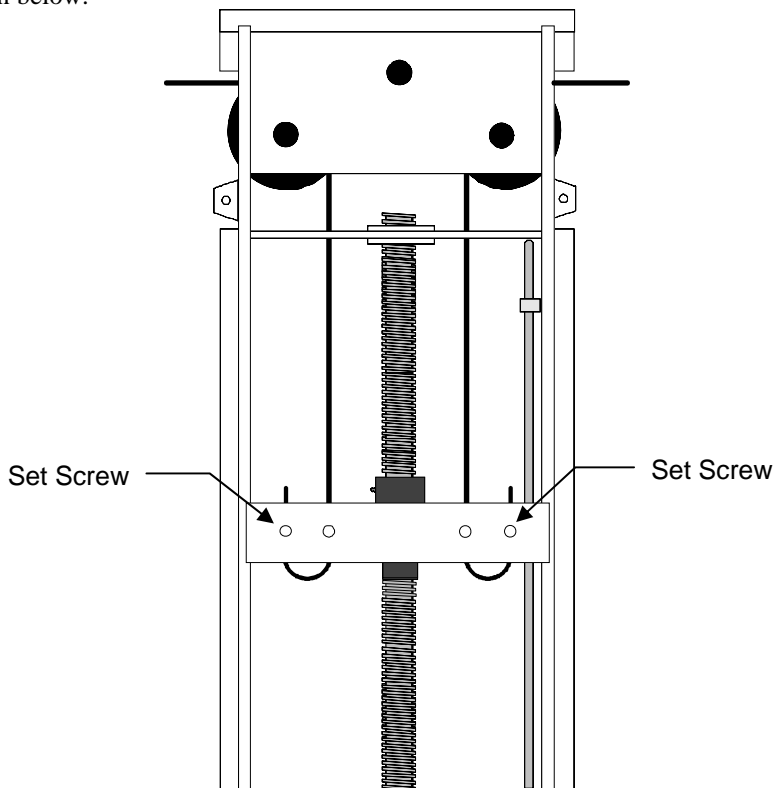

When one PowerTrak is used to pull two curtains loop the cables as shown in figure 1.

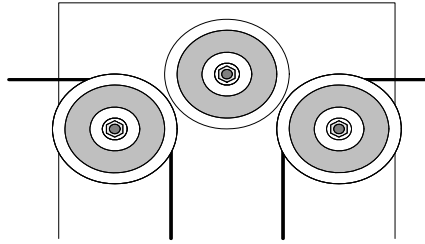

Figure 1

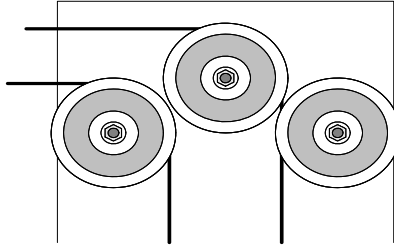

Figure 2

If the PowerTrak will only be pulling to the left side of the machine, loop the cables through the pulleys as shown in figure 2.

If the PowerTrak will only be pulling to the right, loop the cables through the pulleys as shown in figure 3.

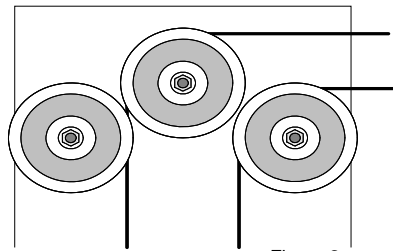
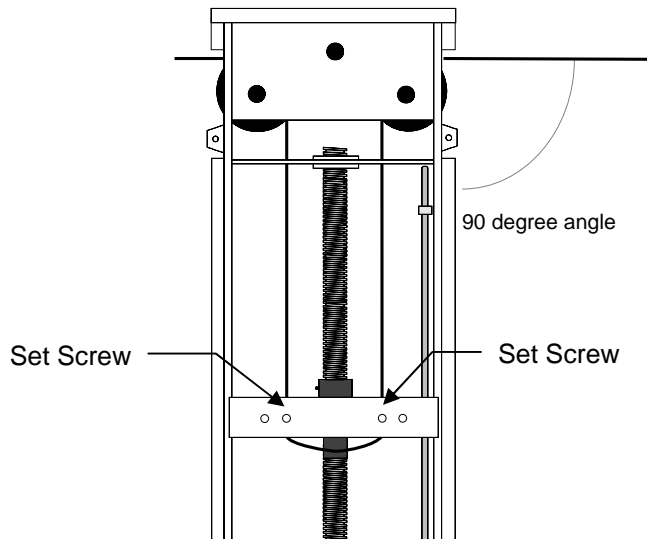
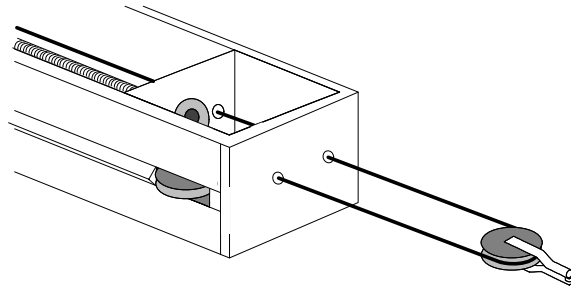

Figure 3

- Note: The cables should come out of the pulleys at a right angle (90 degrees) with the cabinet. This ensures even wear on load block. Changing the exit angle of the cable changes the force seen on that side of the load block.



10. If for any reason it is necessary for you to mount the PowerTrak horizontally, punch the "Knock-outs" and run the cables straight through the top of the machine. It is very important to loop the cable around a needle bearing pulley as seen below to ensure even weight distribution on the Load Block. This pulley also acts as a spacer to keep the cables straight.



11. Hookup electrical wiring as shown in the wiring diagrams in the back of this manual. Note: All wiring must comply with all National and Local Electric Codes.
12. With the controller in manual mode, close the machine fully. Then take up the slack on the cabling with the manual winch. (Note: With the PowerTrak you have the ability to adjust the lower limit switch setpoint, however, our factory setting should be sufficient for most applications.)
13. Next, open the curtains with the manual controls. When the curtain reaches the bottom of the opening, or whichever point you choose, stop curtain motion, and set high adjustment collar (near the top of the machine) on limit switch guide rod to this point. Use an allen wrench for loosening and tightening the setscrew in the collar.
14. Attach a small cable clamp to the cable near the hand winch as a reminder not to wind the cables past this point.

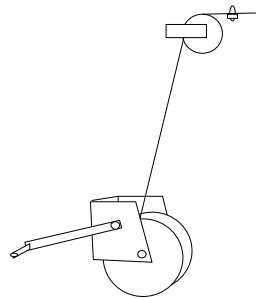

15. Replace the door to protect the machine from the elements.

7. Maintenance

The PowerTrak is designed to operate with a minimum of maintenance. However, the following steps must be performed on a regular basis to ensure peak performance over the unit's lifetime.

The most crucial maintenance item is lubrication. We recommend using Valvoline Val-Plex EP™ wheel bearing grease for this purpose. The full length of the screw, and the "V shaped" tracks on the sides of the cabinet (where the load block runs) should be wiped from top to bottom with grease. There are five grease fittings provided on the PowerTrak, one on the load nut, and one on the thrust bearing (just above the spider coupling), and three on the pulleys in the top. Each bearing should receive two pumps with a grease gun (or until grease appears on both sides of the bearing) at least every 3 months.

To grease the screw, hookup grease gun to the fitting on load nut. Then use the manual setting on the controller to move load nut from one end of the screw to the other while applying grease. This ensures that the full range of the load nut is well lubricated.

Important: Do not use WD-40™ or other similar products for lubrication or cleaning of this machine. Products of this nature will remove grease from the unit, causing excessive wear on load bearing surfaces and increasing the possibility of binding.

It is also important to keep debris out of the enclosure. The door on the unit should be sufficient, but it is still recommended that you do a visual inspection and clean out any wasp nests, etc. It is acceptable to blow debris out of the unit with pressurized air, but never spray the internals with water unless power is completely disconnected from the unit.

Inspect cables periodically, especially at the onset of cold weather. Damaged cables can break, and the risk is higher in colder temperature. Replace any badly frayed or excessively worn cables.

8. Wiring Diagrams, Schematics, etc.

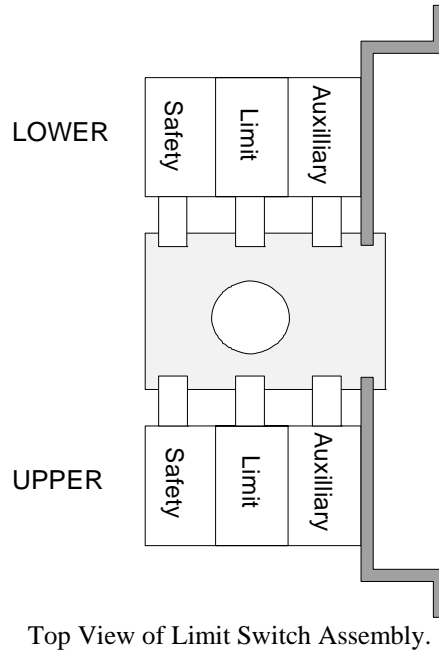

Top View of Limit Switch Assembly.

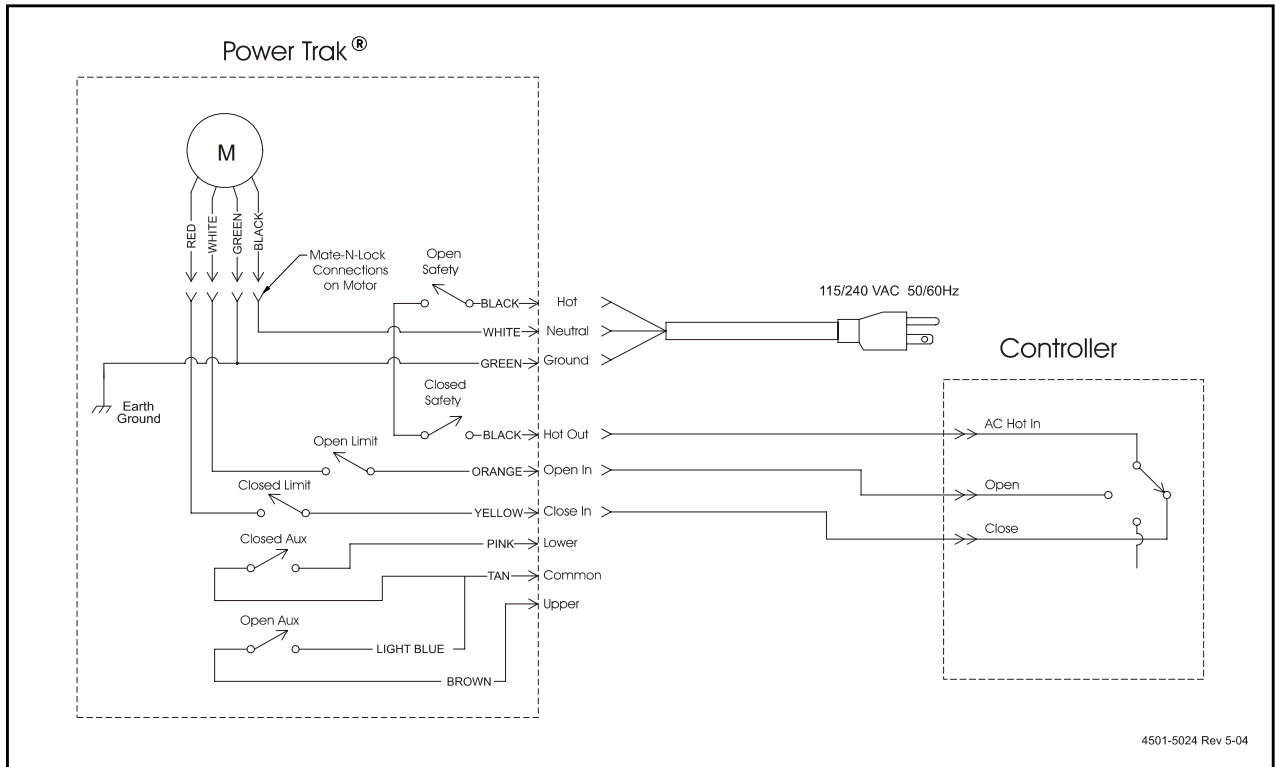

Farm Hand Controllers

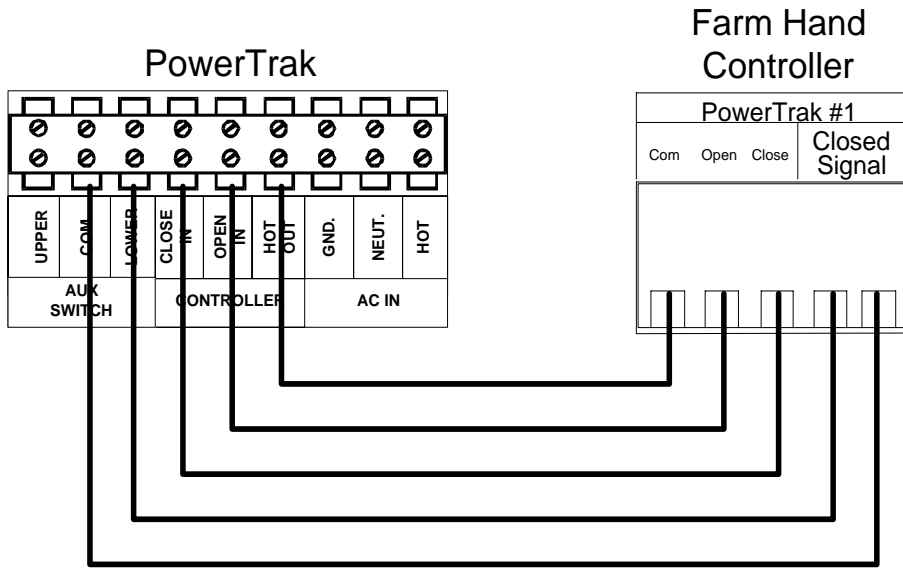

System 500, System 1000, and System 2000 Family of Controllers

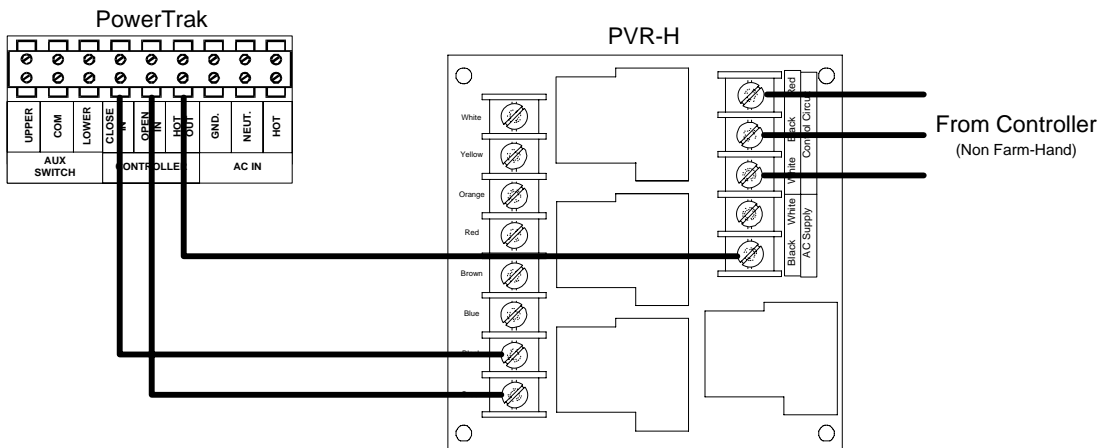

Warning: Be sure that you do NOT connect AC Power To the PVR-H's AC Supply Terminals.

9. Electro-Mechanical Controllers

If you own a PC-OC, PC-SS, PC-D3, PC-DB, PC-LP, PC-OD, PV-TIR, or PC-PH. Your controller wiring diagram may not match the label inside the controller. The only thing different is the label. The internal wiring of these controllers did not change. Your controller will connect to either the 8 wire or the 3 wire PowerTrak.

The picture below is the label you will see for your terminal block.

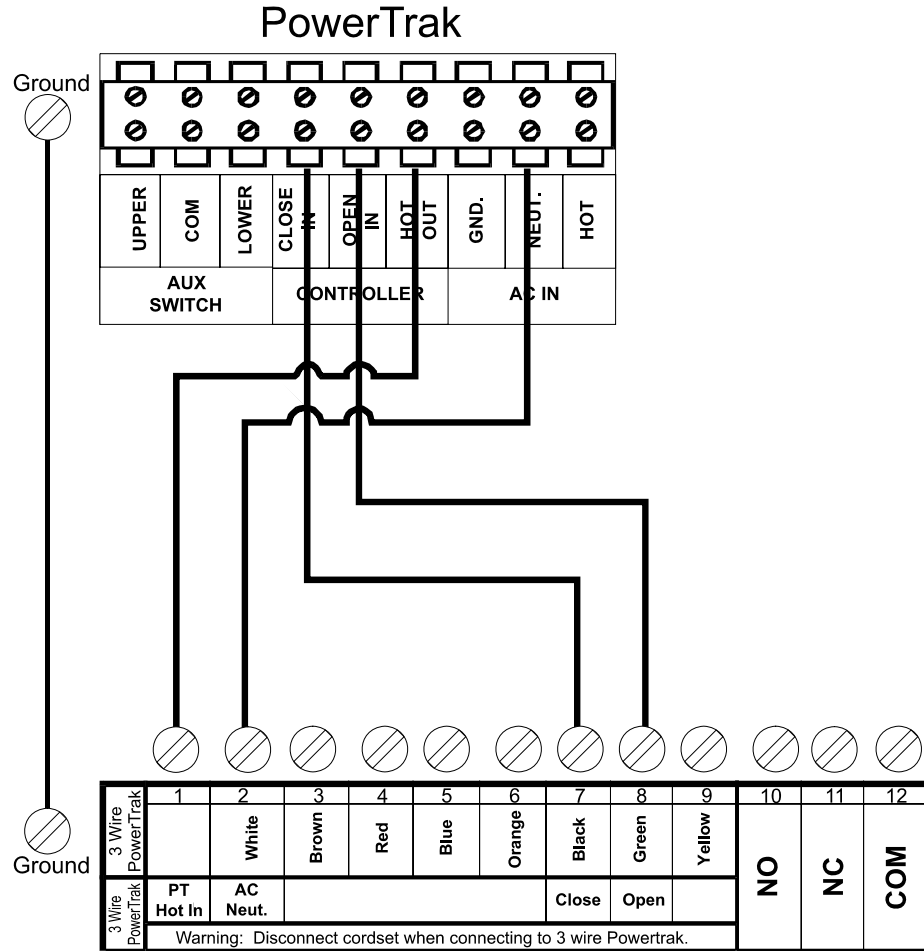

Remove the cordset from the control and remove the fuse wire from the #1 terminal inside the controller. Connect the two units together using 5 wires. positions 1, 2, 7, 8 and GROUND. (*PT HOT IN connects to HOT OUT(PT), AC NEUT connects to NEUT(PT), CLOSE connects to CLOSE IN(PT), OPEN connects to OPEN IN(PT), connect ground from GROUND LUG of PowerTrak to metal plate inside control.*)

10. Cabling Options

Outside Endwall Mount

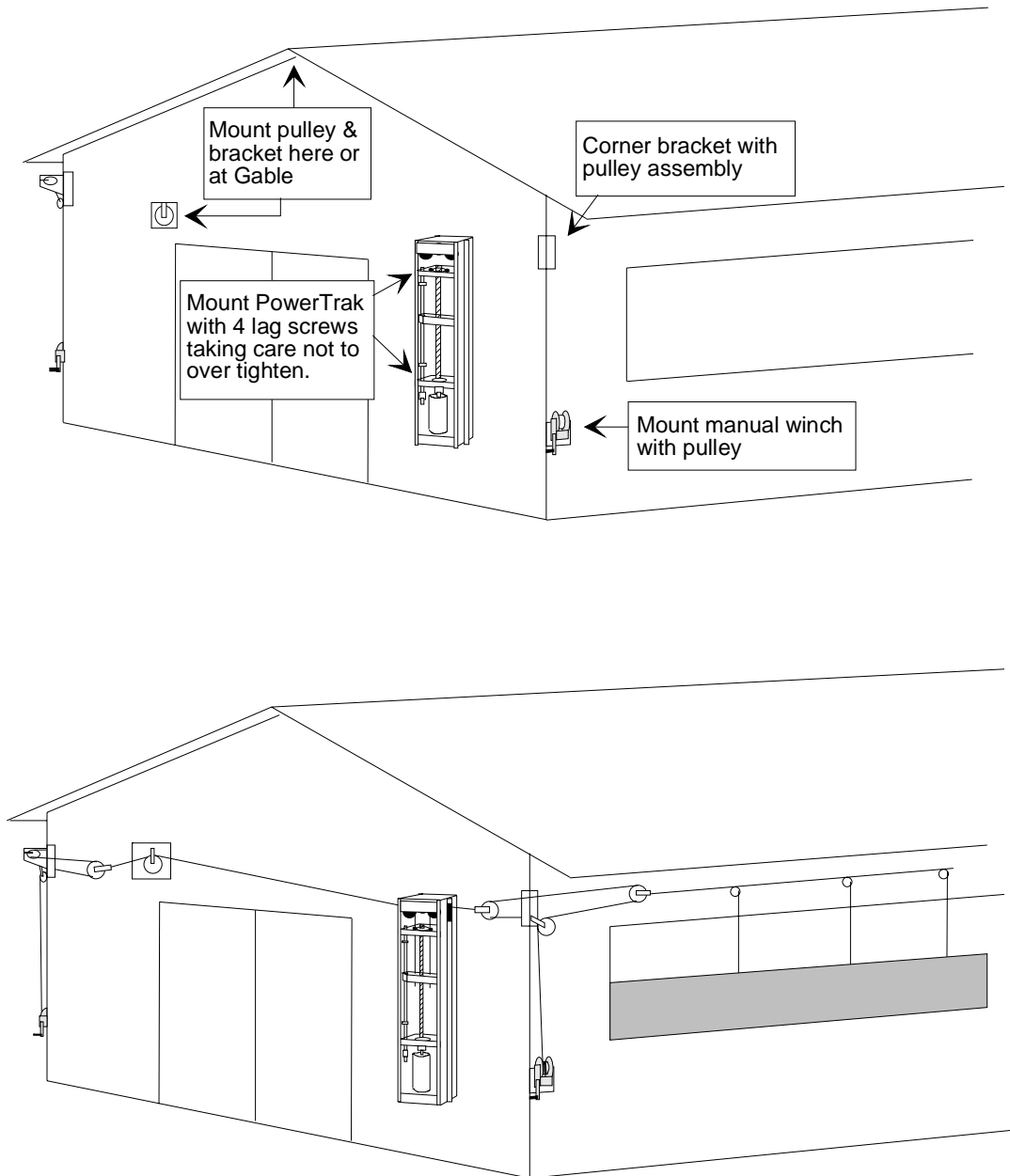

Outside Sidewal Mount

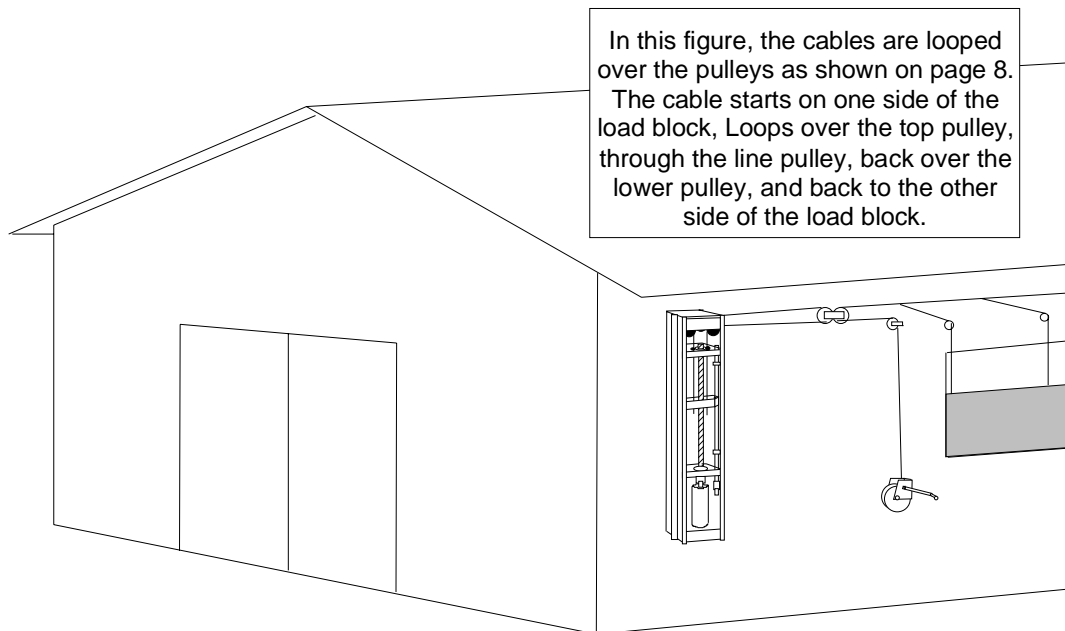

This drawing shows a 1:2 ratio.

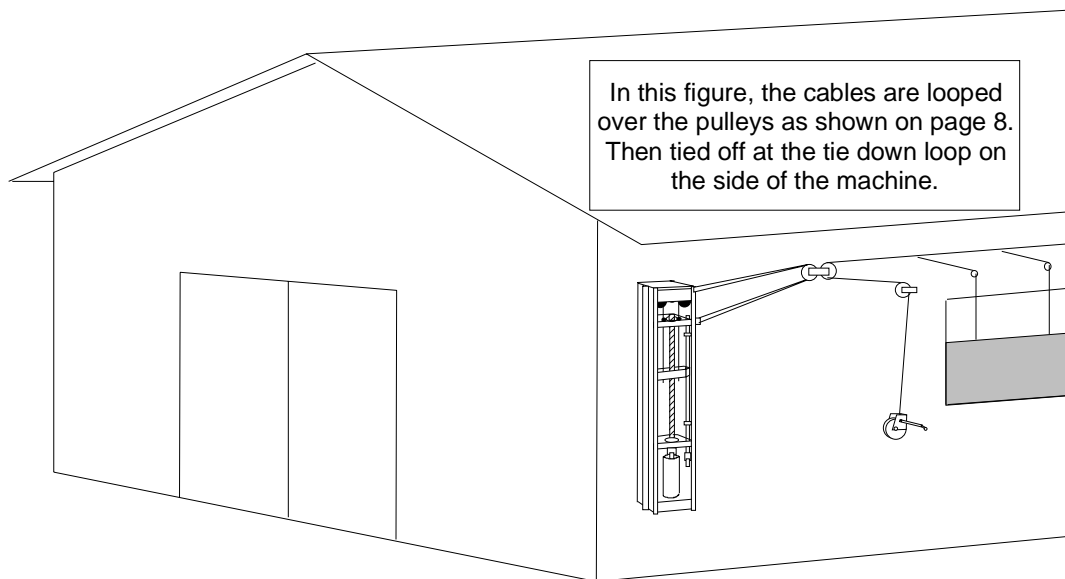

This drawing shows a 1:1 ratio.

PowerTrak operating Curtains on one side of building. (Outside center mount)

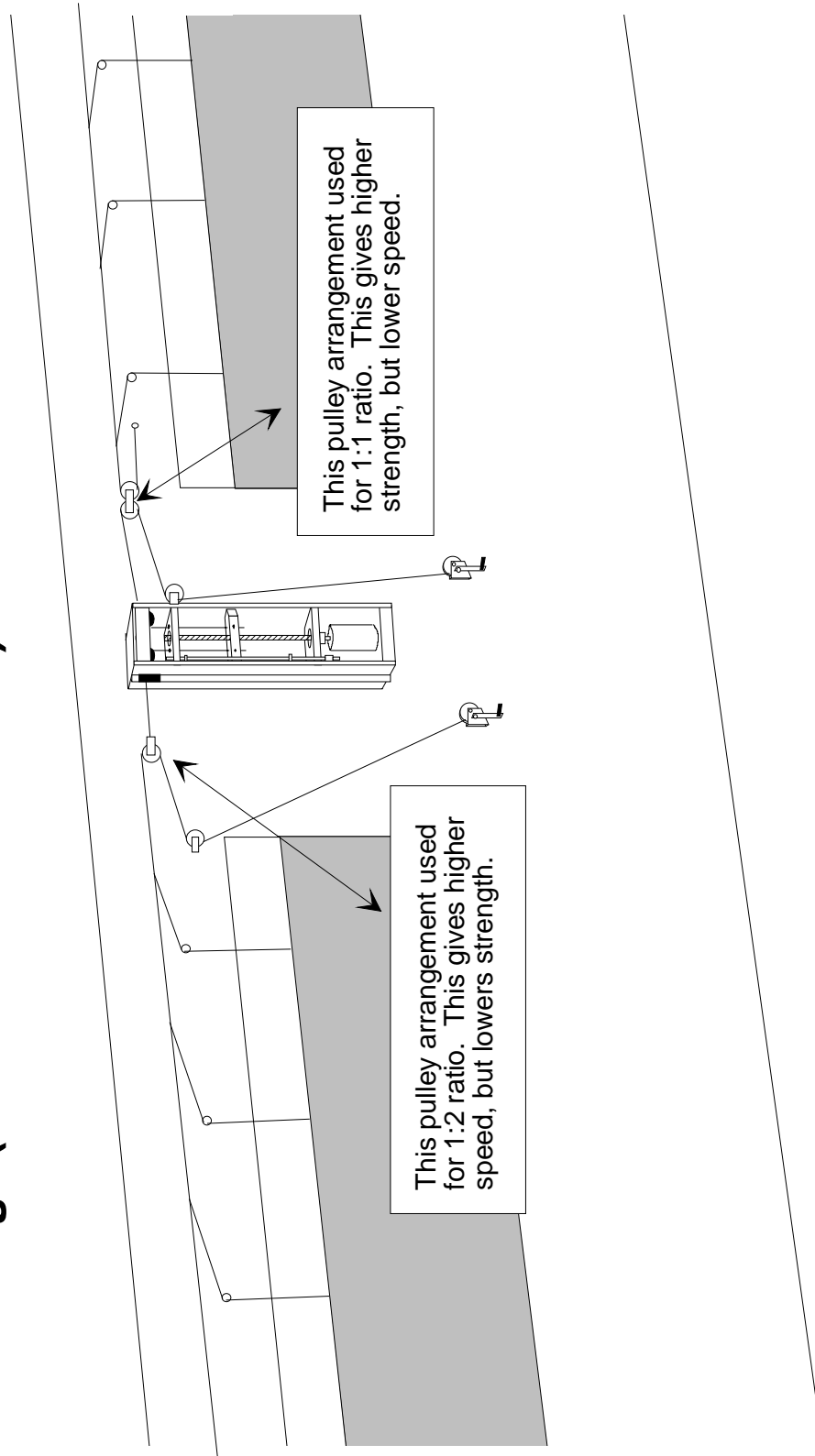

NOTE: Although this drawing shows the two methods of arrangement, ensure that both sides are arranged the same way in your application.

PowerTrak operating vents on one side of building. (inside center mount)

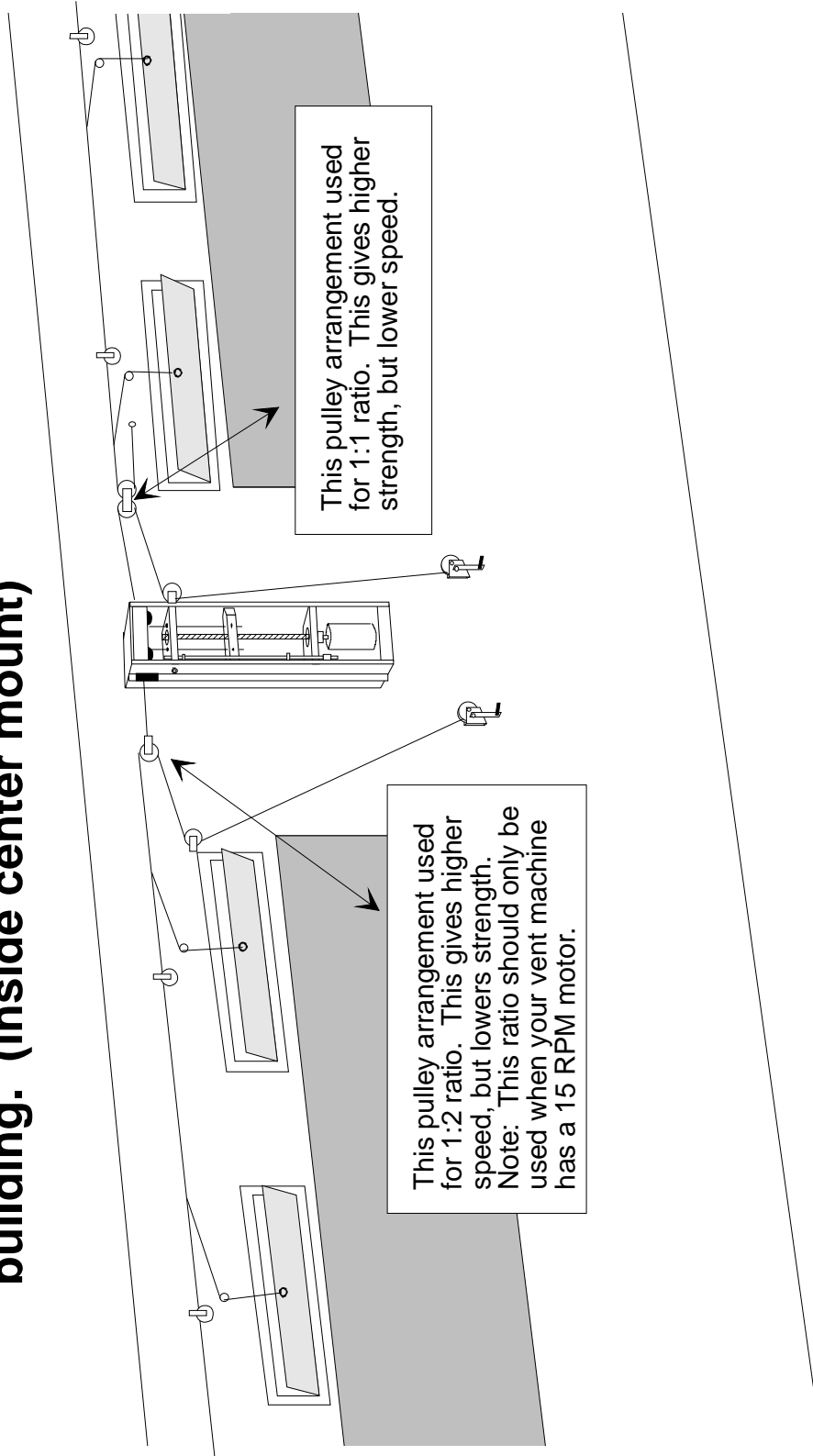

NOTE: Although this drawing shows the two methods of arrangement, ensure that both sides are arranged the same way in your application.

Inside Endwall Mount

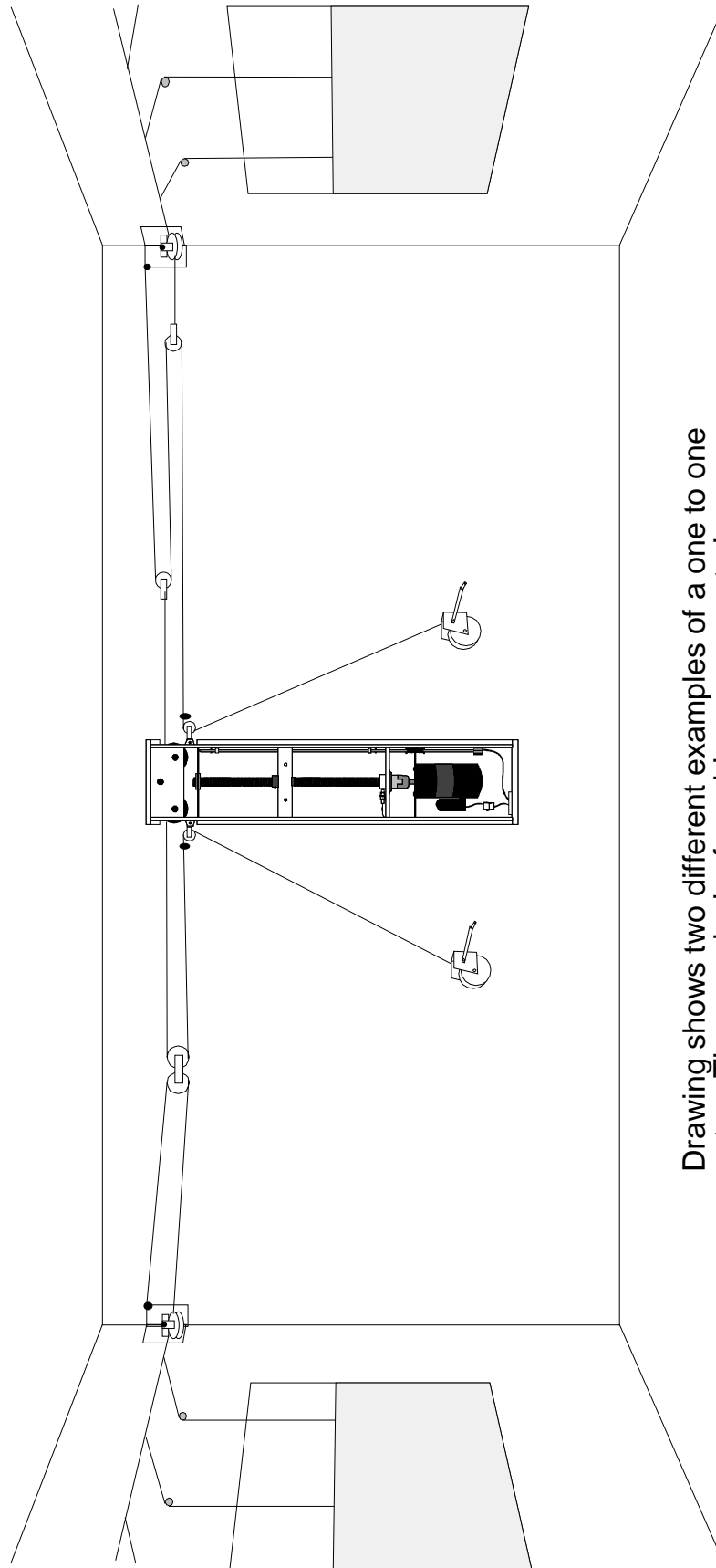

Drawing shows two different examples of a one to one setup. Thus one inch of machine movement gives one inch of curtain movement.

11. Exploded View Diagram/Parts List

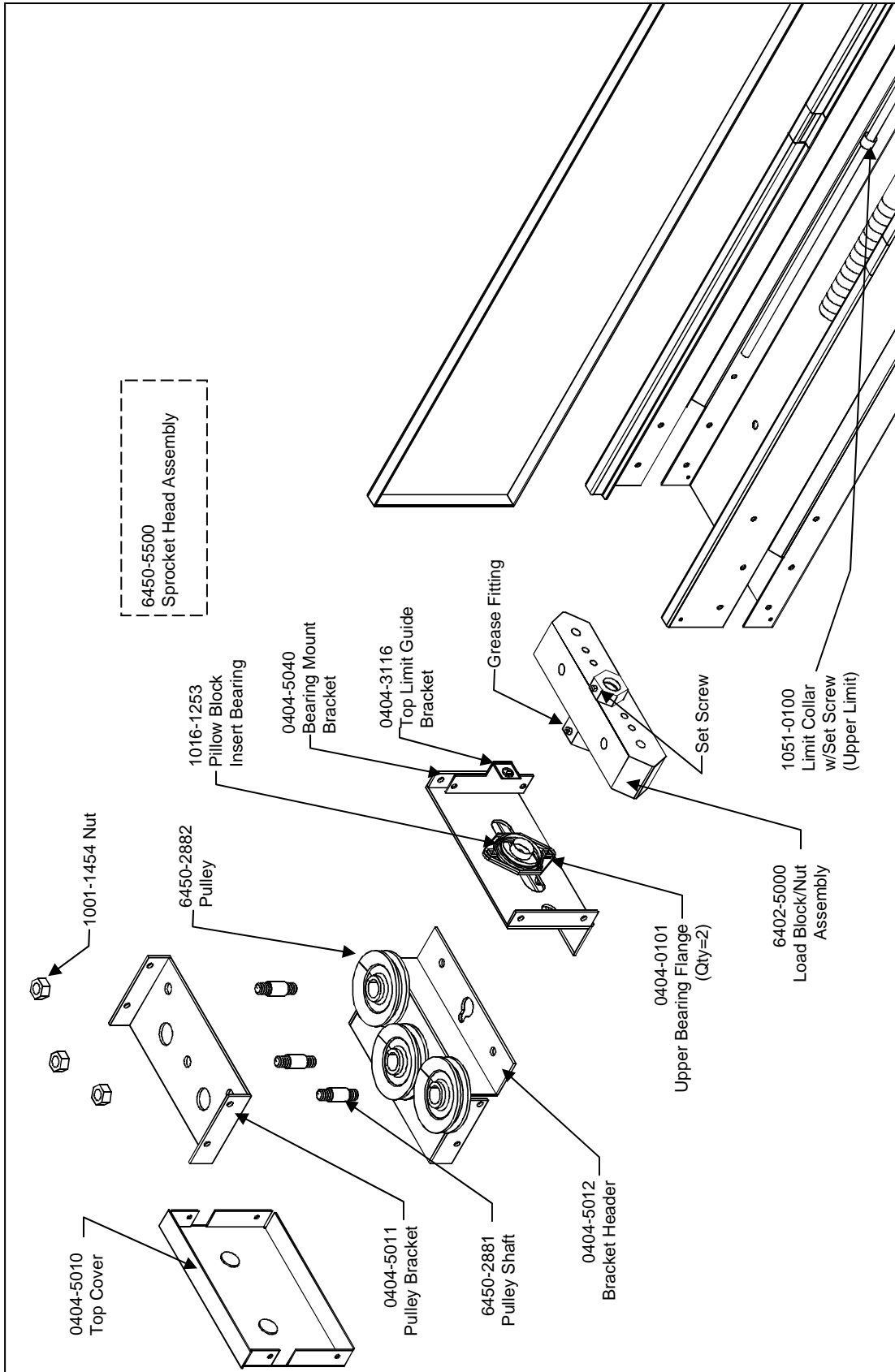

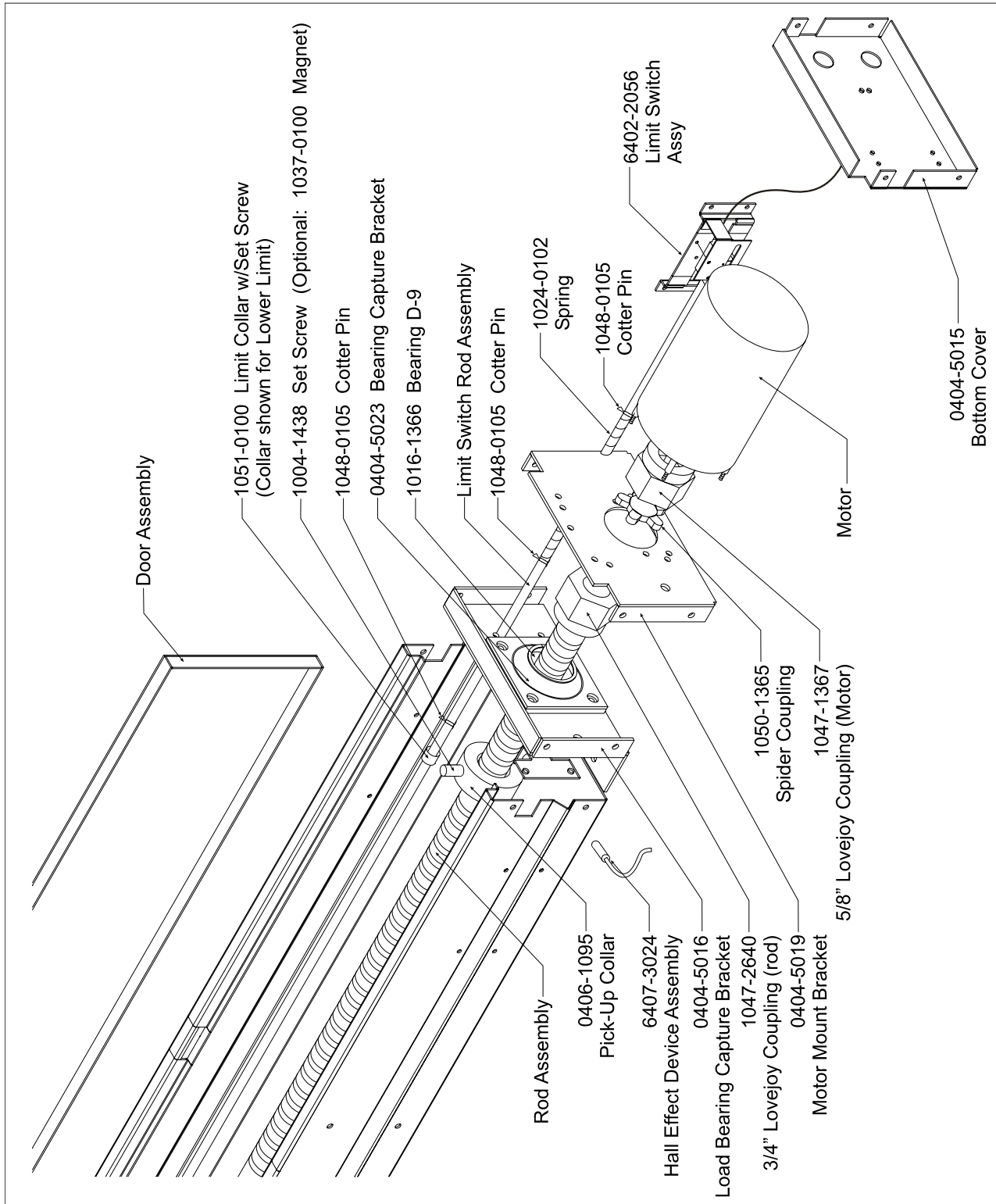

Part No.	Description
6450-2881	/Cast pulley shaft with grease fitting
6450-2882	/Cast pulley sheave with needle bearing
6407-3024	/PT Hall effect device assembly
6402-2056	/PT limit switch & wiring harness for 3 Wire PT
6402-0145	/PT limit switch with formed lever
6402-5000	/PT load block/nut assembly
0401-5027	ALUMINUM cam limit switch PT
0401-3560	ALUMINUM load block PT
1016-1253	BEARING insert pillow block 1"
0409-3561	BRASS bushing load nut heavy duty PT
1051-0100	COLLAR steel 3/8" with set screw PT
1047-2640	COUPLING lovejoy 3/4" (rod) PU/PT
1047-1367	COUPLING lovejoy 5/8" (motor) PU/PT
0404-0101	GALVANIZED_STEEL flange bearing upper PT
1040-5000	LATCH paw spring XL
1040-0100	LATCH pin spring left PT
1040-0101	LATCH pin spring right PT
1037-0100	MAGNET 0.25 X 0.25 neodymium cylindrical PT-H
1001-1454	NUT lock 1/2"-13 tri-lock hex zinc
0406-1095	PLASTIC collar threaded locking PU
1004-0112	SCREW set 1/2"-13X1 socket head cup point stainless
1050-1365	SPIDER coupling lovejoy plastic PU/PT
1024-0102	SPRING 3"X 0.4 ID plated PT
1048-0105	PIN Cotter 3/32"X1.0" Hammerlock
0404-5010	FAB GS Pnl cover top PT
0404-5011	FAB GS Brkt pulley PT
0404-5012	FAB GS Brkt header PT
0404-5015	FAB GS Brkt bottom PT
0404-5016	FAB GS Brkt load/brng capt PT
0404-5019	FAB GS Brkt mount motor PT
0404-5040	FAB GS Brkt bearing mount PT
0404-3116	FAB GS Brkt guide top limit PT
1016-1366	BRNG Thrust face mt 1" (D-9)
6450-5500	Chain & Sprocket Assembly

Motors

Part No.	Description
6650-0062	/KIT Motor 15 RPM Bison 120V
6650-0065	/KIT Motor 15 RPM Bison 240V
6650-0060	/KIT Motor 15 RPM Franklin
6650-0063	/KIT Motor 30 RPM Bison 120V
6650-0066	/KIT Motor 30 RPM Bison 240V
6650-0061	/KIT Motor 30 RPM Franklin
6650-0064	/KIT Motor 60 RPM Bison 120V
6650-0067	/KIT Motor 60 RPM Bison 240V



HIRED-HAND[®]