

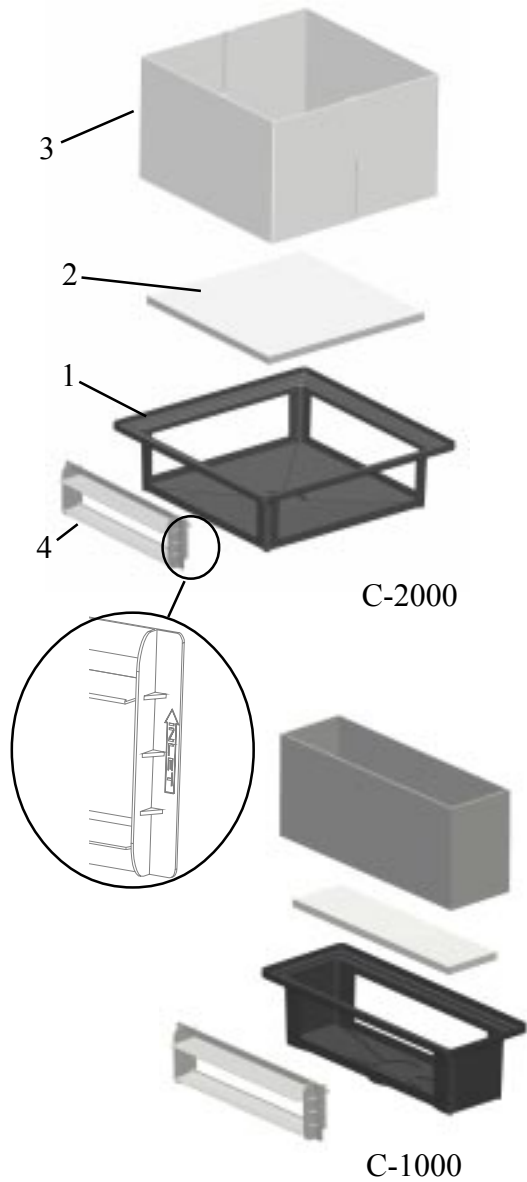

C-2000/C-1000

CEILING INLET INSTRUCTIONS



Step 1. C-2000 Frame rough opening to 29" x 29" square.

C-1000 Frame rough opening to 29" x 9"

Step 2. Place the styrofoam insulation board (2) into the bottom of the C-2000/C-1000 housing (1) Place W-400 inlets (4) see *detail A* into the C2000 housing bottom first then tilt top inward.

Step 3. Place the insulation stop (3) on the inside of the C-2000/C-1000 housing until it comes to rest on the four W-400's. When it is placed, screw the 8 screws per W-400 into the unit.

Step 4. IMPORTANT! Apply foam or caulk between C-2000/C-1000 housing and the ceiling. This must be sealed for proper inlet operation. Mount C-2000/C-1000 assembly to the ceiling (two people may be required). Put screws through plastic housing into framed opening using (8) 1 1/2" screws (Not included). Do not overtighten. All eight screws must be used.

NOTES:

Hole must be drilled centered in bottom of C2000/ C1000 housing to relieve moisture build-up.

Clean louver blades periodically to guard against malfunction.

Counterbalance blade should not be removed.

C-1000

ITEM	QUANTITY	PART NUMBER	DESCRIPTION
1	1	AP-2105	HOUSING FOR C-1000
2	1	AP-3116	INSULATION F/C-1000 26" X 7"
3	1	AP-2107	INSUL. BARRIER FOR C-1000
4	2	W-400	MODULAR INLET - - 400 CFM

C-2000

1	1	AP-2108	HOUSING FOR C-2000
2	1	AP-2488	INSULATION F/C-2000 25" X 25"
3	1	BX-CAI-3.0-1	INSUL. STOP F/CAI-3.0 CORR PLS
4	4	W-400	MODULAR INLET - - 400 CFM